

NEUVIEME COLLOQUE SUR LE TRAITEMENT DU SIGNAL ET SES APPLICATIONS

NICE du 16 au 20 MAI 1983

ANALYSIS OF TRANSMISSION ERRORS IN EMBEDDED DIFFERENTIAL PULSE CODE MODULATION

Carl-Erik Sundberg

David J. Goodman

Telecommunication Theory, University of Lund
Box 725, S-220 07 LUND, SWEDEN

Bell Laboratories, Crawford Hill Laboratory
HOLMDEL, New Jersey 07733, USA

RESUME

SUMMARY

We have derived formulas for the combined effects of quantization and transmission errors on the performance of embedded differential pulse code modulation, a source code that can be used for variable-bit-rate speech transmission. Our analysis is more general and more precise than previous work on transmission errors in digital communication of analog signals. Special cases include conventional DPCM and PCM.

Our main result is a general signal-to-noise ratio formula in which the effects of source characteristics (input signal, codec design parameters) and the effects of transmission characteristics (modulation, channel, forward error correction) are clearly distinguishable. This leads e.g. to computationally-convenient specialized formulas that apply to uncoded transmission through a random-error channel, transmission through a slowly-fading channel and transmission with part or all of the DPCM signal protected by an error-correcting code.

Numerical results show how channel coding can have different effects on conventional and embedded DPCM. They also show how performance is influenced by the binary-number representation of quantizer outputs.



1. INTRODUCTION

Embedded coding can play a valuable role in variable-bit-rate speech transmission. With an embedded code the analog-to-digital and digital-to-analog converters operate at a constant, high bit rate and the transmission system controls the instantaneous rate. Proposed applications for variable-bit-rate operation include a digital private branch exchange, digital speech interpolation, packet switched voice transmission and mobile radio [1].

Sophisticated versions of differential pulse code modulation (DPCM) are promising speech codes for these and other environments [2]. However, conventional DPCM is not suited to variable-bit rate transmission because the decoder amplifies the errors caused by bit-rate reduction. On the other hand, a slightly modified form of DPCM avoids this problem and produces an embedded code [3].

Figure 1 shows the codec (coder, decoder) structure of embedded DPCM. Although up to E bits/sample can be transmitted, the signals presented to the two integrators have a resolution of only M bits/sample, the minimum bit rate of the channel. While Figure 1 is a useful guide to practical implementations, Figure 2, which is equivalent, is easier to analyze. It shows the quantizer at the encoder as a successive-approximation combination of two quantizers: a "minimal" quantizer with M bits/sample and a "supplemental" quantizer with $E-M$ bits/sample, operating on the error signal of the minimal quantizer.

In embedded DPCM, all of the bits from the minimal quantizer arrive at the decoder; the transmission system can delete some or all of the supplemental bits. With S bits/sample of the supplemental quantizer transmitted to the decoder the rate is $D = M+S$ bits/sample and the quantizing distortion is very close to that of a conventional codec with D bits/sample.

Errors in the two bit streams have different effects on the decoder output. Errors in the M minimal bits are enhanced by the decoder integrator which has no effect on errors in the S supplemental bits. This situation compares favorably with conventional DPCM where all errors are integrated at the decoder. It also has implications for forward error correction in embedded DPCM.

2. SIGNAL ANALYSIS

Figure 2 shows the signals that appear in the analysis and defines their notations. We are interested in the overall error signal

$$e(k) = x'(k) - x(k), \quad (1)$$

the difference between decoder output and encoder input. In [4] we have derived the formula

$$e(k) = n_D(k) + e_D(k) + \sum_{i=1}^{\infty} b_i e_M(k-i) \quad (2)$$

where $n_D(k)$ is the quantization noise of the two-stage, D -bit analog-to-digital conversion, $e_D(k)$ is the effect of a transmission error on the entire D -bit transmitted code word and $e_M(k)$ is the effect of a transmission error on the minimal, M -bit DPCM code word. The coefficients b_i are related to the predictor coefficients a_1, a_2, \dots, a_K according to $[1-F(z)]^{-1} = \sum_{i=0}^{\infty} b_i z^{-i}$ with $b_0=1$. Formally $e_M(k) = q_M^i(k) - q_M(k)$ is the difference between the quantized inputs to the decoder and encoder integrators. To define $n_D(k)$ and $e_D(k)$ we view the combined code word with $M+S=D$ bits as a digital representation of $\xi(k) = x(k) - y(k)$. A D -bit digital-to-analog converter produce the quantized signal $q_D(k)$ and so we have the definition of quantization error $n_D(k) = q_D(k) - \xi(k)$. At the receiver, where the D bits/sample are possibly corrupted by transmission errors, a digital-to-analog converter would produce $q_D^i(k)$. The transmission error is $e_D(k) = q_D^i(k) - q_D(k) = e_M(k) + e_S(k)$.

3. MEAN-SQUARE ERROR

To analyze the mean value of the mean square of (2), $E\{e^2(k)\}$, we assume that the sequence $\{x(k)\}$ is drawn from a stationary ergodic random process. In our derivations we ignore all correlations between non-simultaneous samples. That is, we assume $E\{[n_D(k) + e_D(k)]e_M(k-i)\} \approx 0$; $i \geq 1$ and $E\{e_M(k-i)e_M(k-j)\} \approx 0$; $i \neq j$. This says that the overall error (quantizing plus channel distortion) in the k -th sample is uncorrelated with errors in other samples of the minimal M -bit quantized samples. It also says that errors in different minimal samples are uncorrelated. These approximations are accurate because the sequence of samples at the input to a DPCM quantizer is decorrelated by the differential coding process and because transmission errors affecting different code words are independent or only weakly correlated. The approximations remove the last two sums from the expected value, leaving

$$E\{e^2(k)\} = E\{[n_D(k) + e_D(k)]^2\} + b_P E\{e_M^2(k)\} \quad (3)$$

in which we summarize the influence of the prediction in $b_P = \sum_{i=1}^{\infty} b_i^2$. The expectations in (3) are related to the quantization and transmission of $\xi(k)$, the DPCM difference signal. Below we present a complete theory of the errors due to these operations. While this theory relates these errors to $\sigma_{\xi}^2 = E\{\xi^2(k)\}$ we are ultimately interested in the signal-to-noise ratio of the codec input, $x(k)$

$$\text{SNR} = E\{x^2(k)\}/E\{e^2(k)\} = \sigma_x^2/\sigma_e^2 \quad (4)$$

To find this quantity we need $\sigma_x^2/\sigma_{\xi}^2$.

In [4] we have shown that

$$\sigma_x^2/\sigma_{\xi}^2 = G[1 - a_P L^2 \sigma_q^2(M)] \quad (5)$$

where

$$G = \sigma_x^2/E\{[x(k) - \sum_{i=1}^K a_i x(k-i)]^2\} \quad (6)$$

is called the predictor gain and

$$a_P = \sum_{i=1}^K a_i^2 \quad (7)$$

L is the dimensionless load factor $L = \xi_{\max}/\sigma_{\xi}$ where the quantizer overload point is ξ_{\max} . $\sigma_q^2(M)$ is the granular quantizing noise of an M -bit quantizer with unity overload point, derived in the next section.

4. QUANTIZATION AND TRANSMISSION NOISE IN PCM

To analyze (5), we study, statistically, the quantization and transmission of the DPCM difference signal $\xi(k)$. In this type of study it is customary to separate the quantizing error into two components: overload distortion and granular noise. In speech communication this distinction is valuable for predicting subjective quality [8], [9]. Moreover, in analyzing DPCM the distinction is essential because, except for a codec with an ideal integrator [10], there is no theory for computing the mean-square slope-overload distortion. Thus, our analysis separates the transmission of clipped samples of $\xi(k)$ from samples subject to granular distortion. Our theory pertains only to the transmission of unclipped samples. The embedded coded has a fixed overload point (independent of the number of bits transmitted) and we investigate the effects of bit rate and transmission conditions on granular quantizing noise. The remaining analysis will be confined to conditional expectations that we have unclipped samples. To be concise in the remainder of this paper, we will omit the granular condition, $|\xi(k)| \leq \xi_{\max}$, from our notation of expected values. To facilitate numerical evaluation of signal-to-noise ratios we will consider normalized error terms. The normalization relates these errors to a



ANALYSIS OF TRANSMISSION ERRORS IN EMBEDDED DIFFERENTIAL
PULSE CODE MODULATION

quantizer with unity overload point and an input with probability density function $p_u(\cdot)$. If the quantizer of interest has an overload point of ξ_{\max} and the input has the probability density $p_g(\cdot)$, the relevant errors are scaled by ξ_{\max}^2 . The two probability densities are related by $p_u(u) = \xi_{\max} p_g(\xi_{\max} u)$. To confine our attention to the granular quantization condition, we use the scaled variable u confined to the interval $|u| \leq 1$ with probability 1 having the density function

$$p_{gr}(u) = \begin{cases} \frac{p_u(u)}{1} & |u| \leq 1 \\ \int_{-1}^1 p(u) du & \\ 0 & |u| > 1 \end{cases}$$

The signal $u = \xi/\xi_{\max}$ is processed by a B-bit analog-to-digital converter with overload point 1 and step size $\Delta_B = 2^{-(B-1)}$. The digital output of the A/D is i and the corresponding quantized signal is u_i which is related to u by $u_i = -1 + (i+0.5)\Delta_B$ when $-1+i\Delta_B \leq u < -1+(i+1)\Delta_B$, $i = 0, 1, \dots, 2^B-1$. The B-bit code word i is transmitted and i' is received, with the transformation of i to i' characterized by a binary error pattern with index ℓ , ℓ being an integer in the range $0, 2^B-1$.

With u the quantizer input, and ℓ the binary error pattern we denote the received sample $u_{i\ell}$. It is helpful to separate the complete error $u_{i\ell}-u$ into quantization-noise and transmission-noise components as follows,

$$u_{i\ell}-u = (u_i-u) + (u_{i\ell}-u_i) \quad (8)$$

Our goal is to evaluate the mean-square of (8) over the joint distribution of input statistics and binary-error patterns. The key to our analysis is the definition of A-factors which are conditional mean-square errors, each related to a specific binary error pattern, ℓ . By analyzing these conditional errors, we separate the effects of source characteristics from the effects of transmission characteristics. The source effects are embodied in the A-factors; the transmission effects are embodied in probabilities of error patterns. These probabilities govern the weighted addition of the A-factors to produce the final result. This approach to analyzing transmission impairments was introduced by Rydbeck and Sundberg [5], [6], [7], who were mainly concerned with quantizers with 6-8 bits/sample. This high resolution admitted various approximations which are inaccurate in the 2-4 bit quantizers of greatest interest for embedded DPCM transmission.

To compute the mean-square value of (8) conditioned on error pattern ℓ we will identify three important quantities: $\sigma_q^2(B)$, the granular noise power of a B-bit quantizer, $A_\ell(B)$, the mean-square effect of error pattern ℓ on the quantized signal u_i and $\tilde{A}_\ell(B)$, the overall effect of error pattern ℓ on the mean-square error of the analog output $u_{i\ell}$. To derive computationally convenient expressions for $\sigma_q^2(B)$, $A_\ell(B)$ and $\tilde{A}_\ell(B)$ we define

$$p_i = \int_{v_i}^{v_{i+1}} p_{gr}(u) du \quad (9)$$

$$q_i = \int_{v_i}^{v_{i+1}} (u_i-u) p_{gr}(u) du \quad (10)$$

$$\sigma_{gr}^2 = \int_{-1}^1 u^2 p_{gr}(u) du, \quad (11)$$

in which v_i is the lower boundary and v_{i+1} is the upper boundary of quantizing interval i : $v_i = -1 + i2^{-(B-1)}$; $i = 0, 1, \dots, 2^B$.

Now we write the definitions followed by computational formulas for the quantizing noise and the effects of error pattern ℓ :

$$\sigma_q^2(B) = E(u_i-u)^2 = \sigma_{gr}^2 + \sum_{i=0}^{2^B-1} (2q_i u_i - p_i u_i^2) \quad (12)$$

$$A_\ell(B) = E(u_{i\ell}-u_i)^2 = \sum_{i=0}^{2^B-1} p_i (u_{i\ell}-u_i)^2 \quad (13)$$

$$\tilde{A}_\ell(B) = A_\ell(B) + 2 \sum_{i=0}^{2^B-1} q_i (u_{i\ell}-u_i) \quad (14)$$

$\tilde{A}_\ell(B)$, the difference between the total noise and the quantizing noise, includes the correlation between quantization effects and transmission-error effects. In multibit quantizers ($B > 4$) this correlation is small and $\tilde{A}_\ell(B) \approx A_\ell(B)$ an assumption inherent in previous work on PCM. Because low-resolution quantizers are of interest in DPCM we take account of this correlation in our present work. Finally, we combine (12)-(14) to write the mean-square value of (8)

$$\epsilon^2 = E(u_{i\ell}-u)^2 = \sigma_q^2(B) + \tilde{A}_\ell(B) \quad (15)$$

In [4] we have given numerical data for $A_\ell(B)$ and $\tilde{A}_\ell(B)$ factors above. To compute $A_\ell(B)$, $\tilde{A}_\ell(B)$, it is necessary to know $u_{i\ell}-u_i$, which depends on the binary number representation of u_i . We consider two representations: natural-binary and sign-magnitude [4]. In general, the $A_\ell(B)$ and $\tilde{A}_\ell(B)$ depend on p_i and q_i .

Returning now to (3), we have two expectations: the first is the combined (quantizing and transmission) noise of a D-bit signal; the second expectation is the noise due to transmission errors in the M-bit minimal signal. Using the above and combining (3), (4) and (5) we arrive at the signal-to-noise ratio

$$\text{SNR} = \frac{G[1-a_P L^2 \sigma_q^2(M)]}{L^2 [\sigma_q^2(D) + \sum_{\ell=1}^{2^D-1} P(\ell) \tilde{A}_\ell(D) + b_P \sum_{\ell=1}^{2^M-1} P(\ell) A_\ell(M)]} \quad (16)$$

which is the principal result of this paper. With the exception of the two summations in the denominator, all of the quantities in (16) are properties of the input signal and the codec design parameters. These summations,

$$\sigma_{qt}^2 = \sum_{\ell=1}^{2^D-1} P(\ell) \tilde{A}_\ell(D) + b_P \sum_{\ell=1}^{2^M-1} P(\ell) A_\ell(M) \quad (16a)$$

comprise the effects of transmission errors on the performance embedded DPCM.

5. TRANSMISSION EFFECTS, BINARY-ERROR PROBABILITIES

The 2^D probabilities, $P(\ell)$, of binary-error patterns are properties of the digital transmission system which includes a modulator, a channel, a demodulator and possibly, a codec for forward error correction and possibly a means for combining different versions (diversity branches) of the received signal. Depending on these components, the $P(\ell)$ exhibit properties that facilitate evaluation of the sums in (16). For details, see [4].

Assume that errors in all bits are statistically independent of each other and occur with probability P . The probability of error pattern ℓ depends only on w , the Hamming weight of ℓ , i.e., the number of ones in the B-bit binary representation of ℓ . Thus

$$P(\ell) = P^w (1-P)^{B-w} \quad (17)$$



ANALYSIS OF TRANSMISSION ERRORS IN EMBEDDED DIFFERENTIAL
PULSE CODE MODULATION

Expanding (17) leads us to express the summations in (16) as polynomials in P . The coefficients of the polynomial involve the sums of all A -factors with a fixed Hamming weight w . Let us denote these sums $S_w(B)$. Thus

$$S_w(B) = \sum_{\ell_w} A_\ell(B) ; \quad \tilde{S}_w(B) = \sum_{\ell_w} \tilde{A}_\ell(B) \quad (18)$$

where ℓ_w is the set of all error patterns with Hamming weight w . Combining (17) and (18), we can write

$$\sum_{\ell=1}^{2^{B-1}} P(\ell) A_\ell(B) = \sum_{w=1}^B P^w T_w(B) \quad (19)$$

where

$$T_w(B) = \sum_{j=1}^w \binom{B-j}{w-j} (-1)^{w-j} S_j(B) \quad (20)$$

and analogous for $\tilde{T}_w(B)$ expressed in $\tilde{S}_j(B)$.

For the natural-binary and sign-magnitude representations we can prove the surprising result that for any input probability distribution, $T_w(B) = \tilde{T}_w(B) = 0$ for $w > 2$. Thus the transmission term in (16) is

$$\sigma_{qt}^2 = \sum_{w=1}^2 P^w (T_w(D) + b_P \tilde{T}_w(M)) \quad (21)$$

This formula is valid for channels with random binary errors.

For slow fading channels, the binary-error probability is a random variable that is constant over each code word but varies from word to word. In this case the effects of digital errors can be calculated as in (21) but with the average values P^w replacing P^w . These averages are computed over the distributions of channel SNR's that govern the random fluctuation of P from one code word to the next.

To analyze the performance of embedded DPCM protected by an error-correcting channel code, we make three simplifying approximations. The first one, which pertains to the error-correcting code, states that when there is a decoding error, all error patterns are equally likely. Thus we assume that if the C most significant DPCM bits are protected by the code, $P(\ell) = P_e \cdot 2^{1-C}$, $\ell = 1, 2, \dots, 2^C - 1$ and P_e is the bit error probability for the channel code.

The other two approximations apply when $C < D$, so that the C most significant DPCM bits are protected and the other $D-C$ bits are uncoded. To simplify computations for this case, we (1) ignore simultaneous errors in the protected and unprotected parts of the D -bit word and (2) ignore multiple errors in the unprotected part. In [4] we consider separately three different relationships among C , the number of coded bits, D the length of the entire DPCM code word and M the number of bits in the minimal quantizer. First we give the formula for the entire code word protected ($M \leq D = C$). In this case

$$\sigma_{qt}^2 = \frac{1}{2^{C-1}} P_e [\tilde{A}_{\text{sum}}^{(D)}(D) + b_P A_{\text{sum}}^{(M)}(M)] \quad (22)$$

where we define the sum of the first 2^{C-1} A -factors

$$\tilde{A}_{\text{sum}}^{(C)}(D) = \sum_{\ell=1}^{2^{C-1}} \tilde{A}_\ell(D) ; \quad A_{\text{sum}}^{(C)}(D) = \sum_{\ell=1}^{2^{C-1}} A_\ell(D) \quad (23)$$

Ref. [4] contains numerical values of \tilde{A}_{sum} and A_{sum} for the sets of conditions of interest to us here.

Next consider the case $M \leq C < D$. In this event we assume that all of the unprotected bits have the binary-error probability P and that as before the protected bits have binary-error probability P_e . Furthermore we set to zero the probability of simultaneous errors in the protected and unprotected parts of the

code word. (These errors occur with probability related to $P_e P$). We also set to zero the probability of multiple errors in the unprotected part of the code word (which occur with probability less than P^2). Thus we break the first sum in (16) into two parts. The first part accounts for errors in the first C (protected) bits when the other $D-C$ bits are error-free, $\ell = 1, 2, \dots, 2^C - 1$. The second part accounts for single errors in the remaining $D-C$ bits when the first C bits are error free, $\ell = 2^C, 2^{C+1}, \dots, 2^D - 1$. The result is [4]

$$\sigma_{qt}^2 = \frac{P_e}{2^{C-1}} \tilde{A}_{\text{sum}}^{(C)}(D) + P \sum_{i=C}^{D-1} \tilde{A}_{2^i}^{(D)}(D) + b_P \frac{P_e}{2^{C-1}} A_{\text{sum}}^{(M)}(M) \quad (24)$$

Just as we decomposed the first sum in (16) into two parts in the previous case, we similarly decompose the second sum when some of the M minimal bits are unprotected. Thus, the result for $C < M \leq D$ is

$$\sigma_{qt}^2 = \frac{P_e}{2^{C-1}} \left(\tilde{A}_{\text{sum}}^{(C)}(D) + b_P A_{\text{sum}}^{(C)}(M) \right) + P \left(A_{\text{un}}^{(C)}(D) + b_P A_{\text{un}}^{(C)}(M) \right) \quad (25)$$

where $A_{\text{un}}^{(C)}(D) = 4(4^{-C} - 4^{-D})/3$ and analogous for $A_{\text{un}}^{(C)}(M)$, see [4].

6. NUMERICAL RESULTS

All of our numerical results pertain to a Gauss-Markov input signal with adjacent-channel correlation $E\{x(k)x(k+1)\} = 0.85$. The codec uses single integration with coefficient $a_1 = 0.85$ and the load factor, $L = \sqrt{10}$. For this configuration the coding gain is $G = 3.6$. If the embedded codec has a minimal quantizer with $M = 2$ bits, $C_s = G[1 - a_1 L^2 \sigma_q^2(M)]/L^2$ is 0.31. For conventional DPCM $C_s = 0.35$ with 3 bits/sample and 0.36 with 4 bits/sample. Thus the quantizing-noise penalty of the embedded codec is 0.54 dB when 3 bits are transmitted and 0.68 dB when 4 bits are transmitted. As indicated in [3] these penalties increase for higher values of L and a_1 . They decrease rapidly as M increases. In our numerical examples the modulation is coherent phase shift keying in a white-Gaussian-noise channel (one-sided spectral density). We have used punctured $R = 2/3$, $3/4$ convolutional codes with 16 states. The $R = 1/2$ code also has 16 states. P_e is estimated by means of a truncated union bound [11].

Figure 3 shows the performance of embedded DPCM in four transmission environments, all of them employing coherent phase shift keying (CPSK) modulation at 32 kb/s in a white-Gaussian-noise channel. The encoder operates at 32 kb/s (8 kHz sampling, 4 bits/sample) and in format 1 all of this information is transmitted. Figure 3 indicates that when the channel SNR falls below 10 dB, the audio SNR deteriorates rapidly. In format 2, the least significant bit of each DPCM code word is deleted and the remaining 3 bits/sample are protected by a rate $3/4$ convolutional code. Although there is more quantizing noise than in format 1 (the SNR is 6 dB lower in the absence of transmission errors), the convolutional code provides for accurate reception of the transmitted bit stream at channel SNR's down to 3 dB. Going one step further with this approach to channel coding we have format 4 in which 16 kb/s of speech data are transmitted under the protection of a rate $1/2$ code. The threshold of essentially error-free performance is now extended down to a channel SNR of about 0 dB.

In code format 3, the speech transmission rate is 24 kb/s as in format 2 but now only 2 of the 3 bits/sample are protected by the convolutional code which has rate $2/3$. The threshold of curve in Figure 3 is about 1 dB lower than that of curve 2. On the other hand, format 3 is slightly worse than format 2 in intermediate channel conditions (SNR's between 3 and 5 dB). Over this range, format 2 is essentially

ANALYSIS OF TRANSMISSION ERRORS IN EMBEDDED DIFFERENTIAL PULSE CODE MODULATION

error free, while format 3 affected by errors in the unprotected third bit of each code word. The effect is small, however, because these errors are not amplified at the decoder.

With conventional, rather than embedded, DPCM, the corresponding picture, Figure 4, is rather different, especially with respect to format 3. Here channel errors in the unprotected third bit are amplified by the integrator at the decoder. The result is a noticeably lower output SNR relative to format 2 (all three bits protected) when the channel SNR is between 3 dB and 6 dB. On the other hand, in clear channels, the output SNR of conventional DPCM at 24 kb/s (formats 2 and 3) and 32 kb/s (format 1) is about 0.7 dB higher than that of embedded DPCM owing to the greater accuracy of prediction in the conventional encoder.

Without forward-error correction, the noise due to transmission errors is dominated by the effects of single errors in the most significant part of the transmitted code word. With the natural-binary representation, an error in the most significant bit always causes a noise impulse of half the peak-to-peak range of the quantizer. With the sign-magnitude representation, an error in the sign-bit inverts the polarity of the quantized signal, thereby producing a noise impulse of approximately twice the magnitude of the quantizer input. Consequently, quantizers employing the sign-magnitude representation are somewhat less affected by transmission errors than quantizers with the natural-binary representation when the input probability distribution has its mode at zero. This is illustrated in Figure 5 which pertains to uncoded 32 kb/s embedded DPCM transmission. When transmission errors are the dominant source of distortion, signals represented in the natural-binary format are about 2 dB noisier than signals represented by the sign-magnitude format.

REFERENCES

- [1] D.J. Goodman, C-E. Sundberg, "Combined Source and Channel Coding for Matching the Speech Transmission Rate to the Quality of the Channel", *Globecom 82, Conf. Rec.*, pp. B.3.2.1-B.3.2.6.
- [2] Proc. of the 1982 ICASSP, May 1982, Session S8, pp. 954-983.
- [3] D.J. Goodman, "Embedded DPCM for Variable Bit Rate Transmission", *IEEE Trans. on Com.*, July 1980, pp. 1040-1046.
- [4] D.J. Goodman, C-E. Sundberg, "Transmission Errors and Forward Error Correction in Embedded Differential Pulse Code Modulation". In submission to the Bell System Technical Journal.
- [5] N. Rydbeck and C-E. Sundberg, "Analysis of Digital Errors in Non-Linear PCM Systems", *IEEE Trans. on Com.*, Jan. 1976, pp. 59-65.
- [6] C-E. Sundberg, N. Rydbeck, "Pulse Code Modulation with Error-Correcting Codes for TDMA Satellite Communication Systems", *Ericsson Technics*, No. 1, 1976, pp. 1-56.
- [7] N. Rydbeck, C-E. Sundberg, "PCM/TDMA Satellite Communication Systems with Error-Correcting and Error-Detecting Codes", *Ericsson Technics*, No. 3, 1976, pp. 195-247.
- [8] D.J. Goodman, B.J. McDermott, L.H. Nakatani, "Subjective Evaluation of PCM Coded Speech", *BSTJ*, October 1976, pp. 1087-1109.
- [9] B. McDermott, C. Scagliola, D.J. Goodman, "Perceptual and Objective Evaluation of Speech Processed by Adaptive Differential PCM", *BSTJ*, May-June 1978, pp. 1597-1618.
- [10] L.J. Greenstein, "Slope Overload Noise in Linear Delta Modulators with Gaussian Inputs", *BSTJ*, March 1973, pp. 387-421.
- [11] G.C. Clark, J.B. Cain, "Error-Correction Coding for Digital Communications", Plenum Press, 1981.

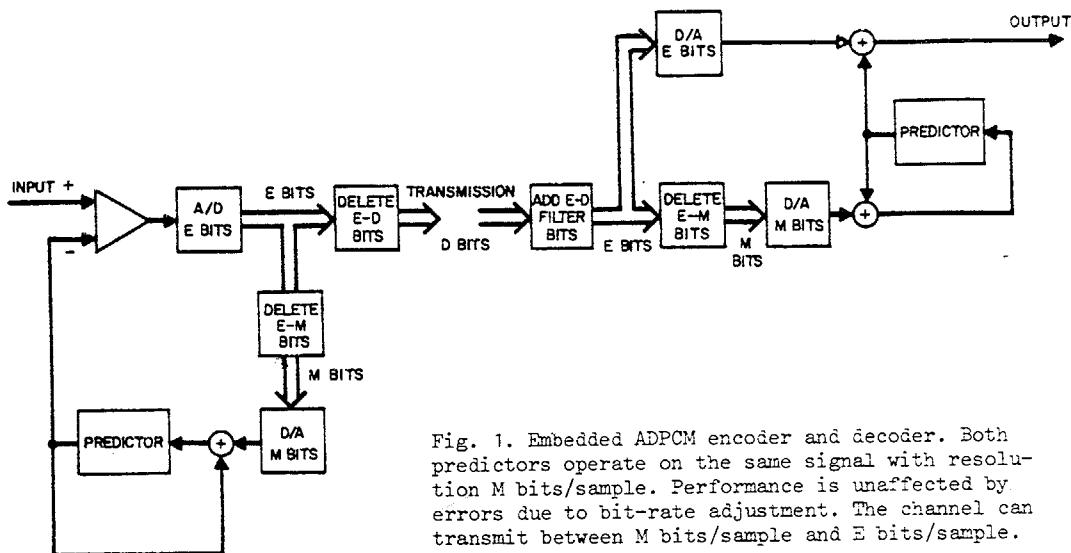

Fig. 1. Embedded ADPCM encoder and decoder. Both predictors operate on the same signal with resolution M bits/sample. Performance is unaffected by errors due to bit-rate adjustment. The channel can transmit between M bits/sample and E bits/sample.



ANALYSIS OF TRANSMISSION ERRORS IN EMBEDDED DIFFERENTIAL PULSE CODE MODULATION

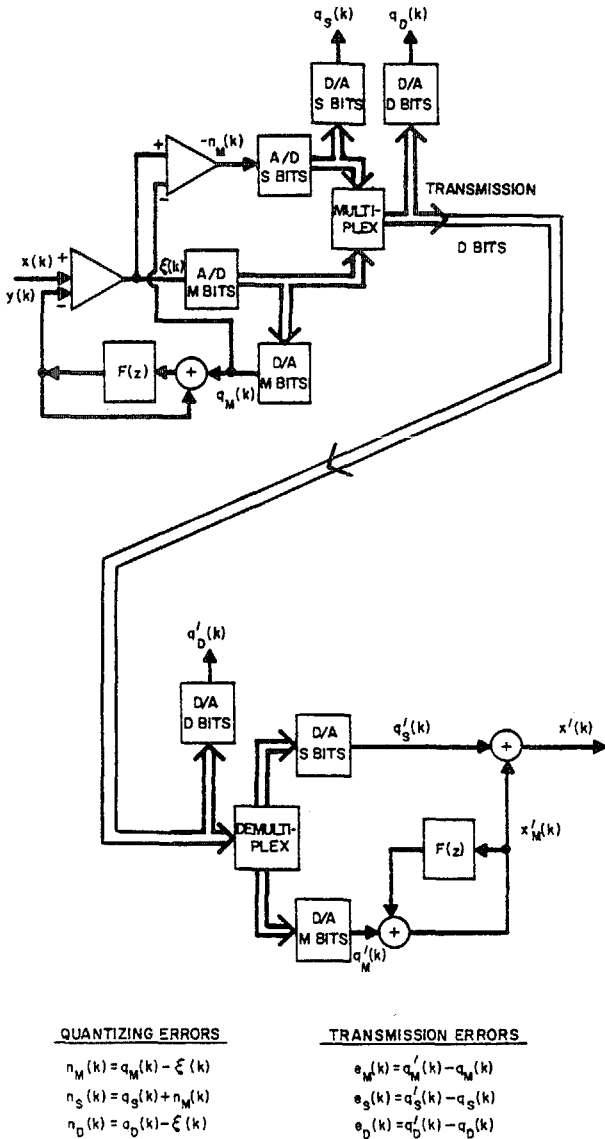

Fig. 2. This arrangement is equivalent to Fig. 1. The signal notation used are shown. Digital-to-analog converters are introduced to define signals that appears in the analysis.

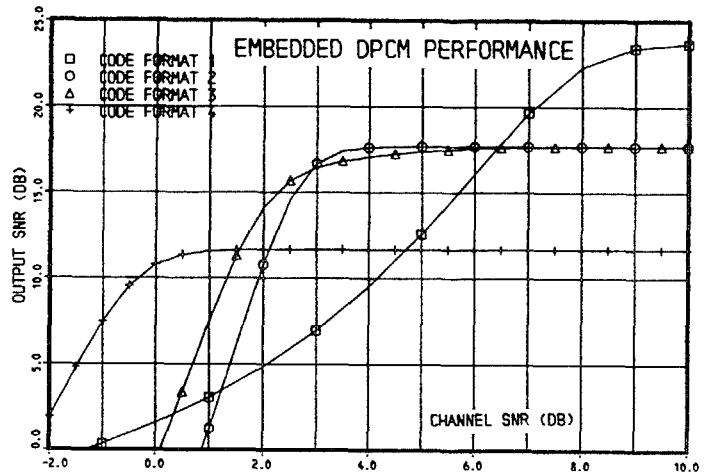
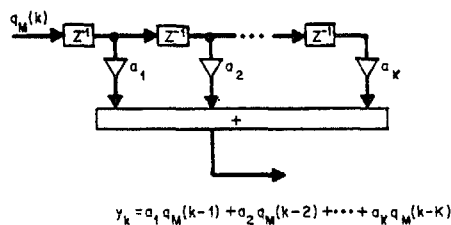

Fig. 3. Audio SNR as a function of channel SNR for 32 kb/s phase-shift keying transmission in a white-Gaussian-noise channel. Format 1: embedded DPCM at 32 kb/s. Format 2: embedded DPCM at 24 kb/s, rate 3/4 convolutional code. Format 3: embedded DPCM at 24 kb/s, rate 2/3 code. Format 4: embedded DPCM at 16 kb/s, rate 1/2 code.

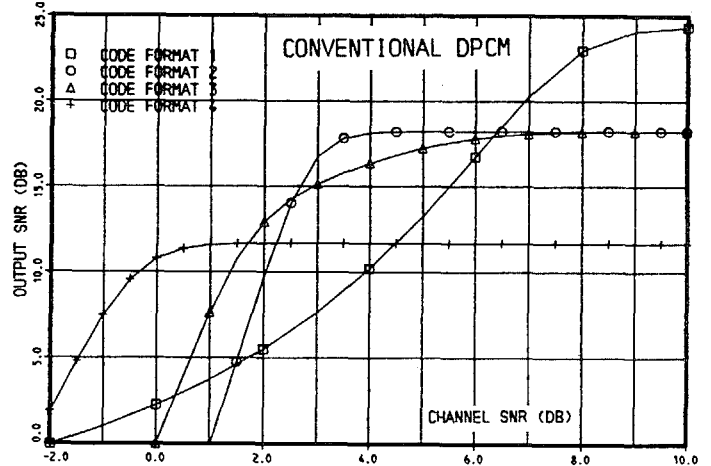

Fig. 4. The same as in Fig. 3 but with DPCM.

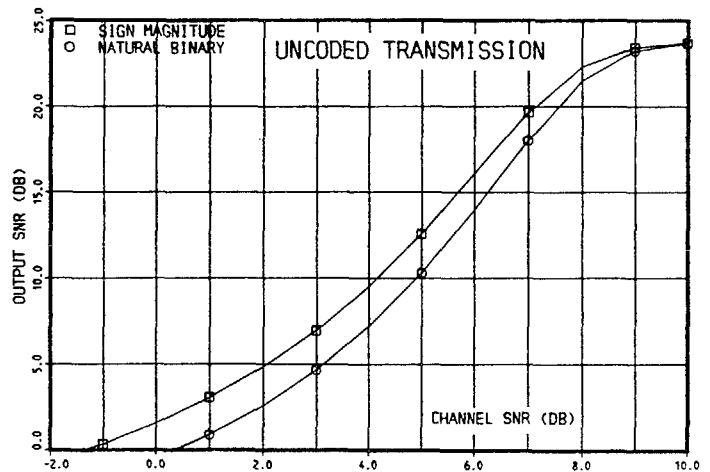

Fig. 5. Performance of embedded DPCM with sign-magnitude and natural-binary representations of quantizer outputs. Because the errors in receiving low-level signals are smaller with the sign-magnitude representation it has an SNR that is about 2 dB higher than natural-binary when performance is controlled by transmission errors.